



OSA ePRTC and ePRTC+

Highly-precise timing solution with unmatched holdover capabilities

Highlights

- **Accurate UTC traceable time**
Within +/-30nsec from UTC when locked to GNSS, compliant with ITU-T G.8272.1
- **Protection against GNSS outages**
Accuracy of holdover time over 14 days: +/-100nsec with ePRC and +/-65ns with ePRTC+
- **Built-in fan-out interface**
Integratgion of ePRTC and grandmaster featuring wide range of output interfaces and protocols such as PTP, NTP, Sync-E over 1/10G as well as PPS, IRIG, BITS
- **Fully redundant hardware design**
All modules can be protected, achieving highest levelsof availability
- **Syncjack™ technology**
Built-in synchronization accuracy monitoring, testing and assurance functionality enabling spoofing detectio
- **Operational simplicity**
Ensemble Sync Director, part of our Ensemble suite,for superior management and synchronizationassurance

Today's critical infrastructure relies predominantly on satellite-delivered timing to synchronize their operational systems and communication infrastructure. Long periods of unavailable Global Navigation Satellite Systems (GNSS) can impact their service and even create outages. Ultra-stable core time clocks in combination with network-delivered timing can efficiently mitigate such risk and significantly improve service quality. Our enhanced primary reference time clocks (ePRTC) eliminate such critical dependency from satellite-delivered timing while providing higher performance levels than standard PRTC systems.

OSA ePRTC and ePRTC+

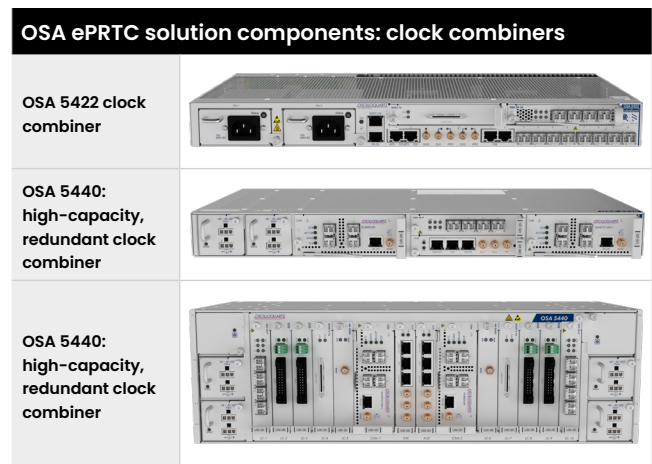
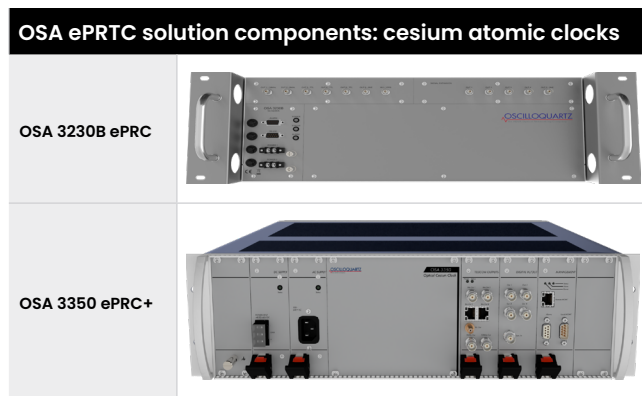

What is an ePRTC?

ITU-T G8272.1 recommendation specifies an ePRTC for ultra-accurate frequency, phase and time synchronization. While current PRTC technology does not need to provide extended holdover, ePRTC is able to provide accurate synchronization overcoming massive GNSS outages lasting for two weeks. What's more, the required accuracy of ePRTCs is significantly exceeding the performance of PRTCs. While the time output of PRTCs should be accurate to within 100ns of Coordinated Universal Time (UTC), this latest generation of time clocks is required to deliver an accuracy of better than 30ns. In short, ePRTCs are the new benchmark in regard to stability, accuracy and reliability for core clocks in critical infrastructures.

How does ePRTC work?

Combining a GNSS receiver with a cesium clock creates an outstandingly accurate time clock with guaranteed holdover performance. Cesium clocks are the most autonomous and stable frequency sources. However, they are not traceable to UTC. On the other hand, GNSS receivers provide long-term traceability to UTC but can be subject to outages and performance degradations. The combination of both technologies provides an accurate, secure, and robust time and frequency source while the GNSS receiver assures tight alignment with UTC timescale. The use of the cesium clock reduces dependency on GNSS and gives operators control of their network synchronization.

OSA ePRTC system overview

The OSA ePRTC solution comprises two OSA devices: an OSA 3230B ePRC or OSA 3350 ePRC+ cesium clock that is connected to an OSA 5422 grandmaster. The cesium clock fully complies with the stringent ITU-T G.811.1 ePRC specification, including maintaining sub-nanosecond time deviation for at least 10,000 seconds. The OSA 5422 is a compact grandmaster integrating a multi-technology GNSS receiver and a clock combiner. Backing up the stable frequency of the cesium clock with the UTC traceable GNSS signal provides extremely accurate and precise timing. The OSA 5422 also offers multiple fan-out interfaces and protocols such as PTP, NTP, SyncE, IRIG and BITS, eliminating the need for additional gateways. What's more, multi-band GNSS receiver option can provide highly reliable and accurate phase and time even under challenging space weather conditions.

Highly-precise timing solution with unmatched holdover capabilities

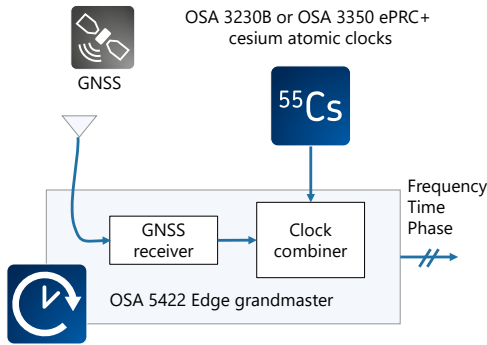

Compact ePRTC solution

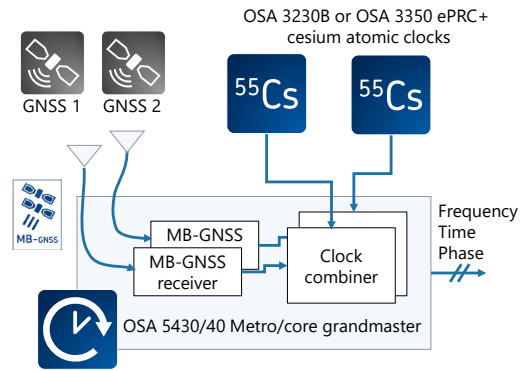

Redundant ePRTC solution

The fully protected OSA ePRTC solution comprises two OSA 3230B ePRC or OSA 3350 ePRC+ cesium clocks connected to an OSA 5430 or OSA 5440 grandmaster. The carrier-grade OSA 5430/40 feature full hardware redundancy, including redundant GNSS receivers and clock combiners. With this modular and scalable design, the OSA 5430/40 offers unique flexibility and highest availability. It supports PTP, NTP and SyncE over multiple 10Gbit/s and 1Gbit/s interfaces with hardware timestamping. What's more, multiple BITS outputs and the multi-band capability of the GNSS receiver makes it a very attractive solution.

It is also possible to design partially protected ePRTC solutions with redundant components using an OSA 3230B ePRC or OSA 3350 ePRC+ cesium clock and an OSA 5430.

ePRTC+ - the better is the enemy of the good

The combination of ultra-accurate cesium clocks with GNSS receivers make ePRTCs the ideal timing source for applications with critical infrastructures such as radio access networks, utility networks, government and military networks, or metrology networks. But, there are still ways to improve accuracy and reliability. Our ePRTC+ solution is based on OSA 5422 or 5430/40 combined with OSA 3350 ePRC+ optical cesium atomic clock technology. The ePRTC+ enhances holdover accuracy and keeps the ePRTC+ phase outputs within 65nsec from UTC over a period of two weeks. The ePRTC+ can also utilize the multi-band GNSS receivers which can compensate ionospheric disturbances to minimize time errors. Unique in our industry, our ePRTC+ solution exceeds even most stringent precision and availability requirements of mission-critical applications.

Key benefits

- Extended holdover capabilities mitigating GNSS disturbances such as jamming or loss of signal
- Easy integration with any G.811.1 ePRC cesium clocks using either 1PPS or clock input
- Spoofing detection leveraging Syncjack™ technology and comparing with information from multi-constellation receivers
- Remote and secure management with Ensemble Controller and Ensemble Sync Director
- Mitigating GNSS issues by concurrently processing multiple constellations such as GPS, GLONASS, BEIDOU and GALILEO
- Optional multi-band GNSS receivers improve accuracy and reduce impact of space weather

G.8272.1 ePRTC holdover versus OSA ePRTC+ holdover

